

TOURMALINE

for 6 percussionists & electronics

PRESTON BEEBE (2012)

INSTRUMENTATION

Percussion 1
 marimba 4.0
 4 wood
 4 drums
 20" timpani
 cymbal on table
 rainstick

Percussion 2
 vibraphone
 4 wood
 4 drums
 23" timpani
 cymbal on table

Percussion 3
 xylophone
 4 wood
 4 drums
 26" timpani
 cymbal on table

Percussion 4
 xylophone
 4 wood
 4 drums
 26" timpani
 cymbal on table

Percussion 5
 vibraphone
 4 wood
 4 drums
 29" timpani
 cymbal on table
 guiro

Percussion 6
 marimba 4.3
 4 wood
 4 drums
 32" timpani
 cymbal on table
 rainstick
 tam-tam

NOTATION KEY

high -- low
1 2 3 4





drums
(drum 3 - snare drum)

woodblocks

cymbal

tam-tam

MALLETS

-  med-hard rubber
(depending on the size of the instrument)
-  soft felt
-  brushes
-  bow

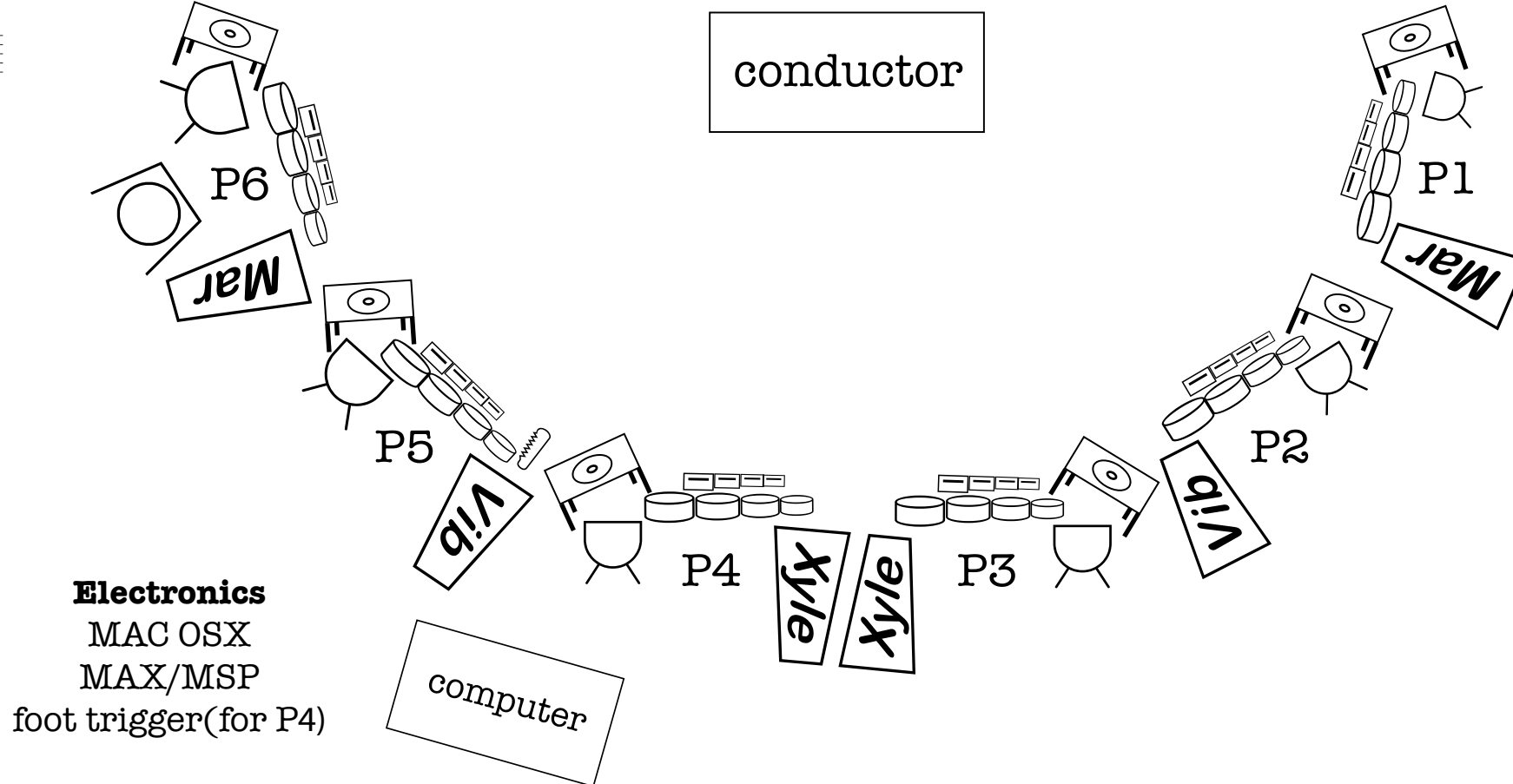

TOURMALINE

Preston Beebe (2012)

23"

A *vigoroso* ♩ = 72
WB

The score consists of seven staves. Percussion 1-6 are marked with 'WB' and dynamic markings of *ff*, *pp*, and *f*. Electronics are marked with circled numbers 1 and 2, and 'SF1'. The score includes various musical notations such as accents, slurs, and articulation marks.

Percussion 1: *ff*, *pp*, *ff*, *pp*, *f*

Percussion 2: *ff*, *pp*, *ff*, *pp*, *f*

Percussion 3: *ff*, *pp*, *ff*, *pp*, *f*

Percussion 4: *ff*, *pp*, *ff*, *pp*, *f*

Percussion 5: *ff*, *pp*, *ff*, *pp*, *f*

Percussion 6: *ff*, *pp*, *ff*, *pp*, *f*

Electronics: ① SF1, ② fade-out SF1

Tourmaline

B

WB+DRUMS

WB+DRUMS

WB+DRUMS

WB+DRUMS

WB+DRUMS

WB+DRUMS

WB+DRUMS

Tam-Tam

SF5

SF6

7

Perc. 1

Perc. 2

Perc. 3

Perc. 4

Perc. 5

Perc. 6

Elec.

13

handle ----- tip

handle ----- tip

handle ----- tip

handle ----- tip

rim w/ rattan
handle ----- tip

handle ----- tip

handle ----- tip

ff > pp

ppp

ff > pp

ffp

ff

ff

pppp

mf

ppp

6

6

7

ff > pp

ff

p

ff

ff

pppp

mf

6

6

6

6

7

7

ff > pp

ppp

ff > pp

ff

p

ff

ff

pppp

mf

5

6

6

6

6

6

ff > pp

ppp

ff > pp

ff

p

ff

ff

pppp

mf

rim w/ rattan
handle ----- tip

6

6

5

ff > pp

ppp

ff > pp

ff

p

ff

ff

pppp

mf

3

3

3

3

3

3

ff > pp

ppp

ff > pp

ff

p

ff

ff

pppp

mf

3

3

3

3

3

3

ff > pp

ppp

ff > pp

ff

p

ff

ff

pppp

mf

6

SF5

3

3

3

3

3

3

p

f

pp

7

SF6

7

3

3

3

3

3

3

ff

pppp

mf

Tourmaline

rit. ----- ♩ = 48 -----

accel. -----

20

Perc. 1
pp *ff* *pppp* *pppp*

Perc. 2
pp *ff* *pppp* *p* *pppp*

Perc. 3
pp *ff* *pppp* *pppp*

Perc. 4
pp *ff* *pppp* *pppp*

Perc. 5
pp *ff* *pppp* *p* *pppp*

Perc. 6
 Marimba
pp *ff* *pppp* *pp* *pppp*

Elec.
 8 SF7 *p*

slow motor

slow motor

Tourmaline

C ♩ = 72

Perc. 1 *ff* *pppp* Rainstick

Perc. 2 *ff* *f* with snares *pppp* stir *snare off*

Perc. 3 *ff* *f* with snares *pppp* stir *snare off*

Perc. 4 *ff* *f* with snares *pppp* stir *snare off*

Perc. 5 *ff* *f* with snares *pppp* stir *snare off*

Perc. 6 *ff* *pppp* Rainstick

Elec. **9 SF8** *pp* *f* **10 SF9** *pppp*

Tourmaline

E ♩ = 72

rit. ----- ♩ = 48

accel. -----

Perc. 1

Perc. 2

Perc. 3

Perc. 4

Perc. 5

Perc. 6

Elec.

13 SF11

ppp

Tourmaline

60

Perc. 1

Perc. 2

Perc. 3

Perc. 4

Perc. 5

Perc. 6

Elec.

molto rit.

pppp *f* *ppp* *mf* *ppp*

pppp *f* *ppp* *mf* *ppp*

pppp *f* *ppp* *mf* *ppp*

pppp *f* *ppp* *mf* *ppp*

pppp *f* *ppp* *mf* *ppp*

pppp *f* *ppp* *mf* *ppp*

15 SF13

The musical score is arranged in six staves for Percussion 1 through Percussion 6, and one staff for Electric Percussion. The score begins at measure 60. Percussion parts 1-6 feature complex rhythmic patterns with various articulations and dynamics. Percussion 1 starts with a 7-measure rest, followed by sixteenth-note patterns with accents and slurs. Percussion 2-6 follow similar rhythmic motifs. The Electric Percussion part is mostly silent, with a single note marked '15 SF13' in the final measure. The score includes dynamic markings such as *pppp*, *f*, *ppp*, and *mf*, and a tempo marking of *molto rit.* at the end. The time signature changes from 4/4 to 6/4 and back to 4/4.

Tourmaline

a tempo ♩ = 72

66

Perc. 1
ff dampen *pp* *ff* *ff p pp* *f*

Perc. 2
ff dampen *pp* *ff* *ff p pp* *f p*

Perc. 3
ff dampen *pp* *ff* *ff p f* *f*

Perc. 4
ff dampen *pp* *ff* *ff p p f* *p*

Perc. 5
ff dampen *pp* *ff* *ff p pp* *p*

Perc. 6
ff dampen *pp* *ff* *ff p* *p*

Elec.
16 SF14 **17 SF15** **18 SF16**

G

WB+DRUMS *stick shot* WB

Marimba

Drums Timp

Drums Timp

Guero

Vibe *motor accel*

Marimba

73

Drums

Perc. 1

p > *pp* *pp* < *ff*

pp

cym on timp

Drums

Perc. 2

pp < *ff*

Xylo aprox. rhythm

Drums

Perc. 3

pp < *ff*

ppppp 3 *pppp* 5 *ppp* 7 *pp* 6 *p* 6 6 6

Xylo aprox. rhythm

Drums

Perc. 4

pp < *ff*

ppppp 7 5 *pppp* 7 *ppp* 5 7 *pp* 6 7 *p* 3

Drums

Perc. 5

pp < *ff*

Drums

Perc. 6

>pp *pp* < *ff*

cym on timp

pp

19 F17

20 SF18

Elec.

80

Perc. 1

Perc. 2

Perc. 3

Perc. 4

Perc. 5

Perc. 6

Elec.

WB aprox. rhythm

ppppp

pppp

ppp

pp

ppp

mp

mf

mp

p

pp

ppp

6 6

3 5 7 6 6 6 6

6 5 6

7 5

7 5

7 5 7

6 6 6 6 6 6 6 5 6 6

7 5 7 6 7 6 7 3

21 SF19

3/4

I *a tempo* ♩ = 72

Drums

Perc. 1

Perc. 2

Perc. 3

Perc. 4

Perc. 5

Perc. 6

Elec.

24 fade-out SF21

Tourmaline

J WB+DRUMS

Musical score for Percussion 1-6 and Electric Bass, measures 98-103. The score is divided into two systems by a double bar line at measure 99. The first system (measures 98-99) is in 4/4 time, and the second system (measures 100-103) is in 3/4 time. The percussion parts are labeled Perc. 1 through Perc. 6, and the electric bass part is labeled Elec. The score includes various dynamics such as *f*, *pp*, *ff*, and *p*, and includes articulation marks like accents and slurs. Fingerings (3, 5, 6, 7) are indicated for several notes. The 'WB+DRUMS' label is repeated in boxes above the Perc. 2, 3, 4, 5, and 6 staves in the second system. The Elec. part consists of a single line with a double bar line at measure 99 and rests in measures 100-103.

This musical score is for a percussion ensemble, consisting of six individual percussion parts (Perc. 1-6) and an Electric Percussion (Elec.) part. The score is written in a grand staff format, with each part on its own set of staves. The music is in 4/4 time and features a complex, rhythmic pattern with frequent changes in dynamics and articulation. The dynamics range from *pp* (pianissimo) to *ff* (fortissimo). The score includes various rhythmic figures, including eighth and sixteenth notes, and rests. The Electric Percussion part is represented by a single staff with a double bar line and a sharp sign, indicating a specific sound effect or electronic trigger.

The score is divided into measures, with the first measure starting at measure 104. The percussion parts are labeled Perc. 1 through Perc. 6, and the Electric Percussion part is labeled Elec. The score includes various dynamic markings such as *ff*, *pp*, and *ff*, and includes articulation marks like accents and slurs. The score also includes various rhythmic markings such as 5, 6, 7, and 3, indicating the number of notes in a group or the length of a note.

118 *molto rit.-----a tempo*

Perc. 1 *f* *pp* *mf* *f* *pp* *fpp* *f* *pp* *fpp*

Perc. 2 *f* *pp* *mf* *f* *pp* *fpp* *f* *pp* *fpp*

Perc. 3 *f* *pp* *mf* *f* *pp* *fpp* *f* *pp* *fpp*

Perc. 4 *f* *pp* *mf* *f* *pp* *fpp* *f* *pp* *fpp*

Perc. 5 *f* *pp* *mf* *f* *pp* *fpp* *f* *pp* *fpp*

Perc. 6 *f* *pp* *mf* *f* *pp* *fpp* *f* *pp* *fpp*

Elec. **Shepard**
25 SF22

L *a tempo* ♩ = 72
WB

Perc. 1
ff *f > p* *p < f > p* *ppp*

Perc. 2
ff *f > p* *p < f > p* *f > p* *f > p* *f > p* *f > p* *ppp*

Perc. 3
ff *f > p* *p < f > p* *p* *f* *ppp* *f > ppp* *f > p*

Perc. 4
ff *p < f* *p < f* *f > p* *p < f* *f > p* *f > p* *p < p < f p < f p < f* *p < f p < f > p f > p*

Perc. 5
ff *p < f* *p < f* *p* *f* *p < f* *p*

Perc. 6
ff *p* *fp* *f* *p* *f* *p* *f* *p* *f* *p* *f* *p* *f* *p* *f* *p* *f* *p* *f*

Elec.
 (26) fade-out SF22

M

136

Perc. 1: Marimba

Perc. 2: Vibe

Perc. 3: Xylo

Perc. 4: Xylo

Perc. 5: Vibe

Perc. 6: Marimba

Elec.

Measures 136-140. Percussion parts include Marimba, Vibe, Xylo, and Electric Percussion. Dynamics range from *p* to *ff*. Time signatures change from 3/4 to 4/4.

Musical score for Percussion 1-6 and Electric Bass. The score is divided into six percussion parts (Perc. 1-6) and an Electric Bass (Elec.) part. The percussion parts feature complex rhythmic patterns with various articulations and dynamics. The Electric Bass part includes specific performance instructions for samples SF23, SF24, and SF25.

Perc. 1: Starts at measure 141. Dynamics: *ff* (measures 141-27), *pp* (measures 28-41). Includes **WB+DRUMS** markings.

Perc. 2: Dynamics: *ff* (measures 141-27), *pp* (measures 28-41). Includes **WB+DRUMS** markings.

Perc. 3: Dynamics: *ff* (measures 141-27), *pp* (measures 28-41). Includes **WB+DRUMS** markings.

Perc. 4: Dynamics: *ff* (measures 141-27), *pp* (measures 28-41). Includes **WB+DRUMS** markings.

Perc. 5: Dynamics: *pp* (measures 28-41). Includes **WB+DRUMS** markings.

Perc. 6: Dynamics: *pp* (measures 28-41). Includes **WB+DRUMS** markings.

Elec.: Includes performance instructions: **27 SF23**, **28 SF24**, and **29 SF25**.

Tourmaline

rit. ----- $\text{♩} = 48$ *accel.* -----

146

Perc. 1

Perc. 2

Perc. 3

Perc. 4

Perc. 5

Perc. 6

Elec.

30 SF26

Timp 7

Tempo: ♩ = 72
46"

Perc. 1
152
5
6 7
fff

Perc. 2
6 7 7
Timp Drums
fff

Perc. 3
7 7 6
Timp Drums
fff

Perc. 4
7 6 5
Timp Drums
fff

Perc. 5
7 6 5
Timp Drums
fff

Perc. 6
6 5 3
Drums
fff

Elec.
31 SF27 32